

# 4A SERIES

ROCKER SWITCH

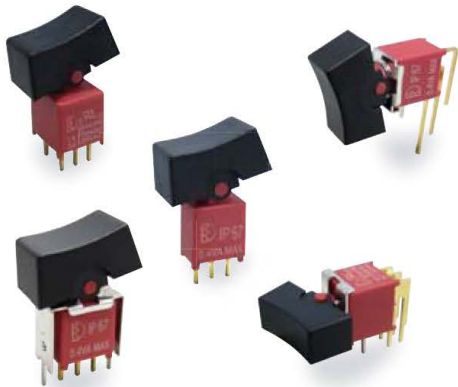

## SPECIFICATIONS

**CONTACT RATING:** Dependent upon contact material See Page 74.

**MECHANICAL LIFE:** 30,000 make-and-break cycles.

**CONTACT RESISTANCE:** 20mΩ max. initial @ 2-4VDC  
100mA for both silver and gold plated contacts.

**INSULATION RESISTANCE:** 1,000 MΩ min.

**DIELECTRIC STRENGTH:** 1,000 Vrms min.@sea level.

**OPERATING TEMPERATURE:** -30°C to 85°C.

## MATERIALS

**CASE & BUSHING :** Glass filled nylon 6/6, flame retardant, heat stabilized (UL94V-0).

**ACTUATOR:** Nylon, black std. Internal O-ring seal standard with all actuators.

**SWITCH SUPPORT:** Brass or steel, tin plated.

**TERMINAL/CONTACT:** Silver or gold plated copper alloy.  
(See Page 74)

IP 67  
ACCORDING TO  
EN 60529:1991+A1:2001  
IEC 60529:2001



## SWITCH FUNCTION

NO. POLES	UL/CSA MODEL NO.	MODEL NO.	SWITCH FUNCTION			CONNECTED TERMINALS / SCHEMATIC		
			POS.1	POS.2	POS.3	POS.1	POS.2	POS.3
SP	Q24A11	4AS1	ON	NONE	ON	2-3	N/A	2-1
	Q24A12	4AS2	ON	NONE	MOM			
	Q24A13	4AS3	ON	OFF	ON		OPEN	
	Q24A14	4AS4	MOM	OFF	MOM			
	Q24A15	4AS5	ON	OFF	MOM	OPEN	N/A	3-1
	Q24A16	4AS6	OFF	NONE	ON			
DP	Q24A21	4AD1	ON	NONE	ON	2-3,5-6	N/A	2-1,5-4
	Q24A22	4AD2	ON	NONE	MOM			
	Q24A23	4AD3	ON	OFF	ON		OPEN	

MOM=MOMENTARY

## POLE OPTIONS

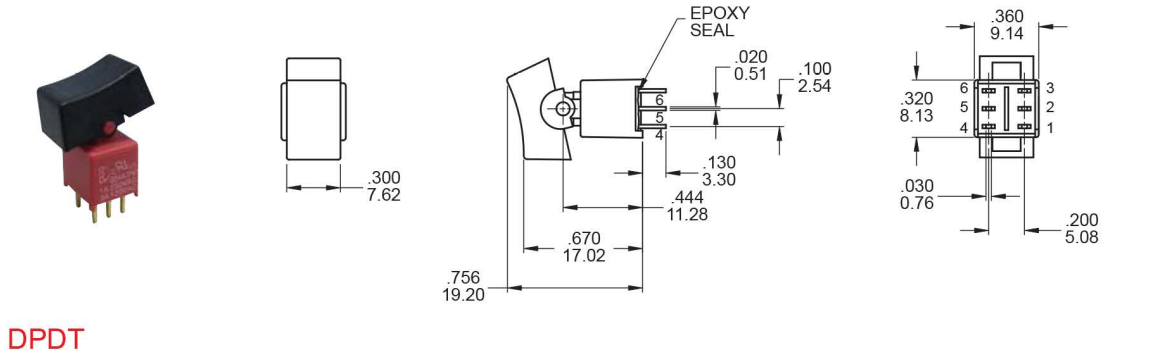
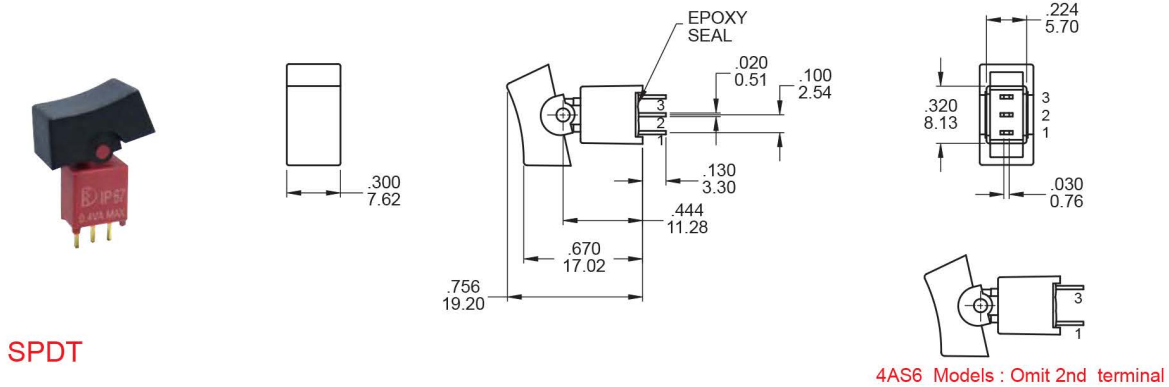

## ACTUATOR OPTIONS - PANEL MOUNT

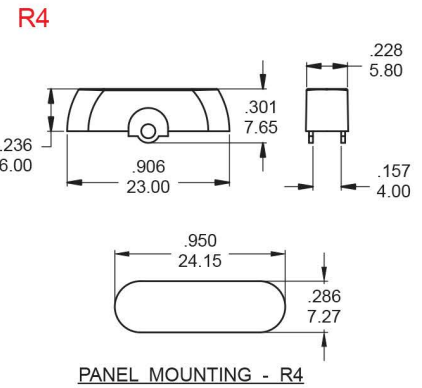
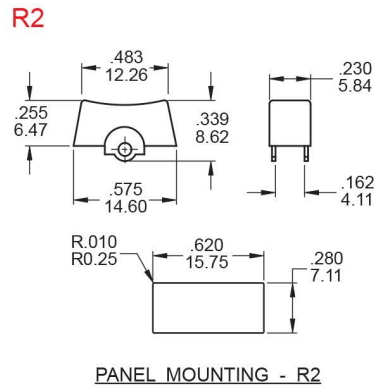
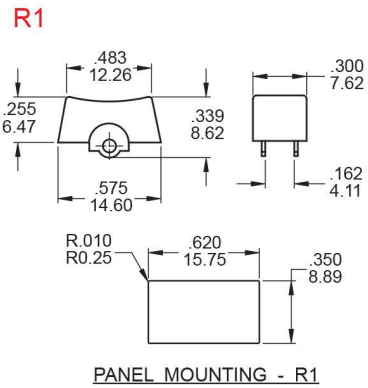

## TERMINATION OPTIONS

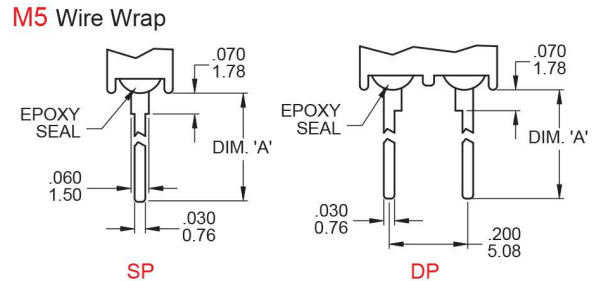
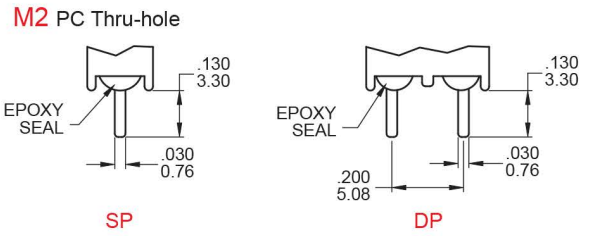

## OTHER TERMINATION OPTIONS

- M6** Right angle P.C. Mount
- M7** Right angle P.C. Mount
- VS2** Vertical bracket P.C. Mount
- M6N** Right angle P.C. Mount with snap-in bracket
- M7N** Right angle P.C. Mount with snap-in bracket
- V2N** Vertical bracket P.C. Mount with snap-in bracket

OPTION CODE	DIM. 'A'
M51	.614 ( 15.60 )
M52	.236 ( 6.00 )

**M6**

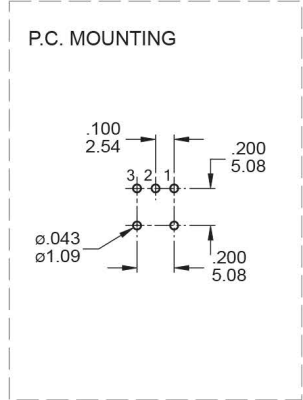
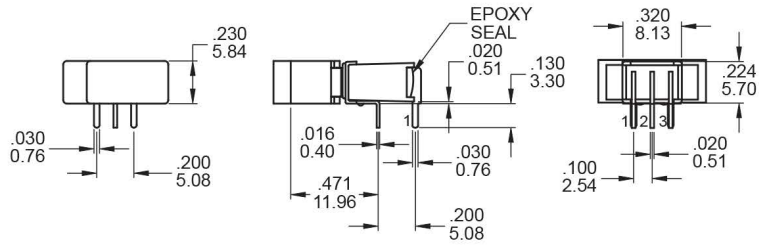

**SPDT**

**M6**

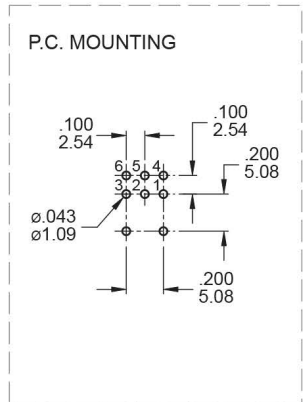
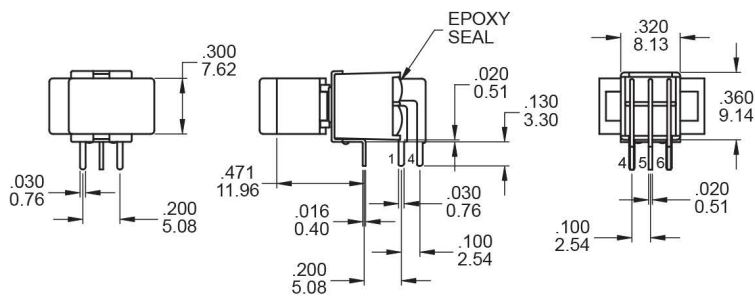

**DPDT**

**M7**

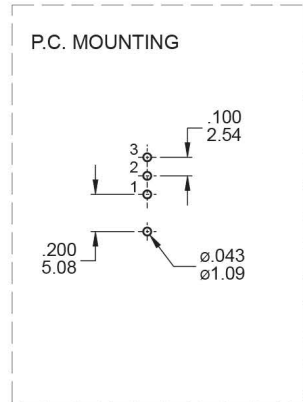
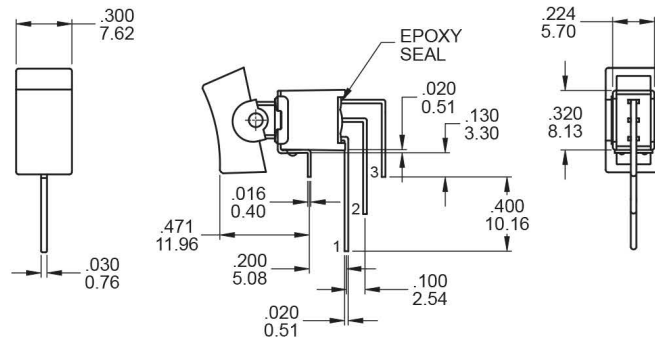

**SPDT**

**M7**

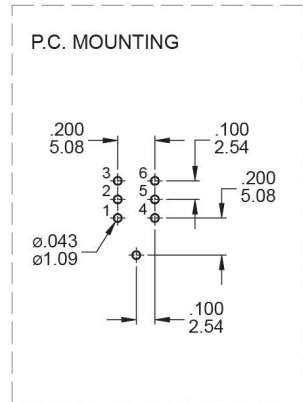
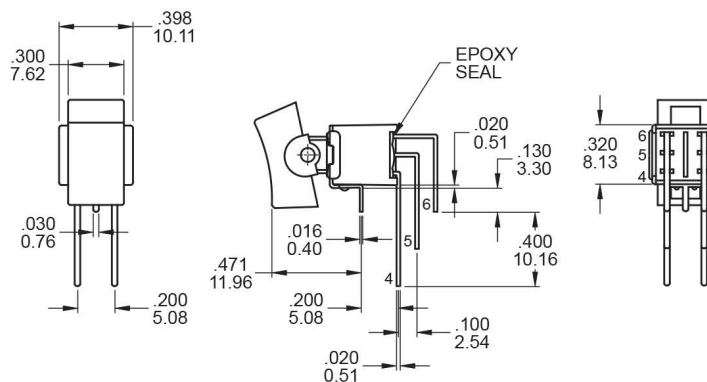

**DPDT**

**VS2**

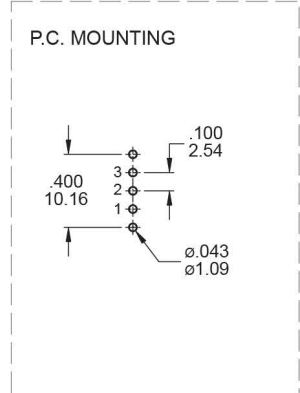
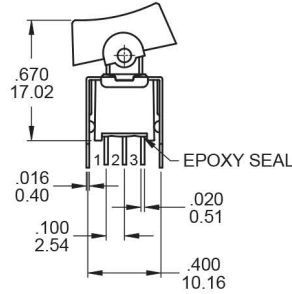
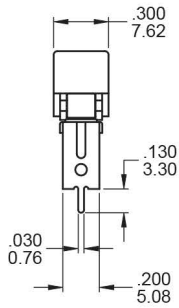

**SPDT**

**VS2**

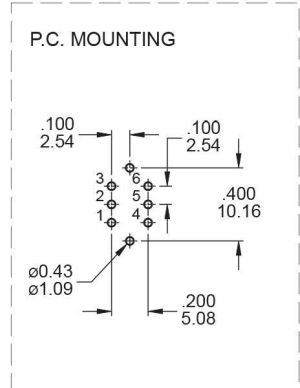
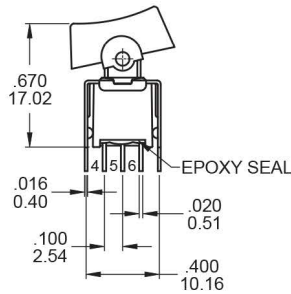
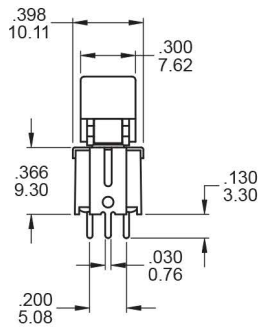

**DPDT**

**SNAP-IN TERMINATION OPTIONS**

**M6N**

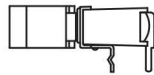
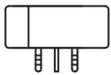

**M7N**

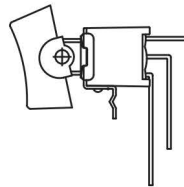
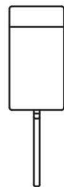

**V2N**

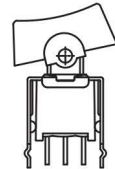

**CONTACT MATERIAL OPTIONS**

	CONTACT PLATING	TERMINAL PLATING	RATINGS
<b>Q</b>	Silver	<b>Q</b> = Gold flash over silver	3 Amps with resistant load @ 120VAC or 28VDC 1 Amps with resistant load @ 250VAC
<b>C</b>	Gold over Silver	<b>C</b> = Gold over silver	
<b>R</b>	Gold	<b>R</b> = Gold	0.4 Volt - Amps ( VA ) max. @ 20V max. ( AC or DC )

**SOLDERING PROCESSES**

**MANUAL SOLDERING:** Use soldering iron of 30 watts, controlled at 350°C approximately 5 seconds while applying solder.

**WAVE SOLDERING:** Recommended Soldering Temperature: 270 ± 5°C

Duration of Solder Immersion: Max 5 sec. (PCB is 1.6mm in thickness)